

BIZERBA

■ ... closer to your business

... Firm grip on everything guaranteed ...

... Bizerba fully-automatic slicer A 510
with integrated scales



A 510
BIZERBA

The new fully-automatic slicer A510 combines decorative depositing pattern with industrial performance. The integrated weighing function can be switched on later or right from the beginning enabling precise portioning to weight. And if a packaging machine is added, a complete production line can be set up.

... automatically more options ...

The robust slicer made of stainless steel is always used when high throughput and special efficiency are required – wherever convenient operation at more product safety is requested.

This is what you have always imagined.

Bizerba A 510 makes processing of symmetrical as well as irregular products as easy as falling off a log. Large pieces of ham and product lengths of up to 600 mm can be handled easily; with a throughput of a maximum of 250 slices per minute – in case of small product diameters this throughput is multiplied by factor 2, 3 and 4 in parallel operation. The product is clamped, the feed is activated, and that's it. At recommended temperatures of -4 °Celsius to +7 °Celsius usually without chilling, shingled or stacked, at a constant slicing thickness as well as constant number of slices. Two independent drives for blade and blade arm guarantee the highest of quality whereby the type of depositing can be flexibly adapted to the trays or packaging sizes available. Optically convincing and highly productive.



BIZERBA

... up to 15 % less give-away ...

Cutting and weighing combined in one machine

The automatic slicer A 510 cannot only cut, shingle or stack meat, sausage and cheese. For the first time, it can also weigh during the same working step. Even in case of natural products, clean cut goods can be produced reducing give-away to almost zero - a feature that pays off, portion by portion, day by day, year by year.

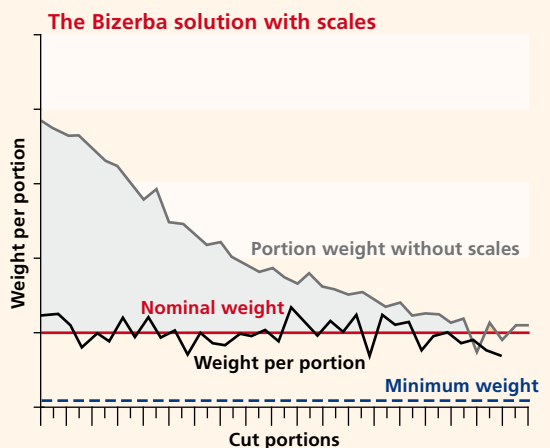
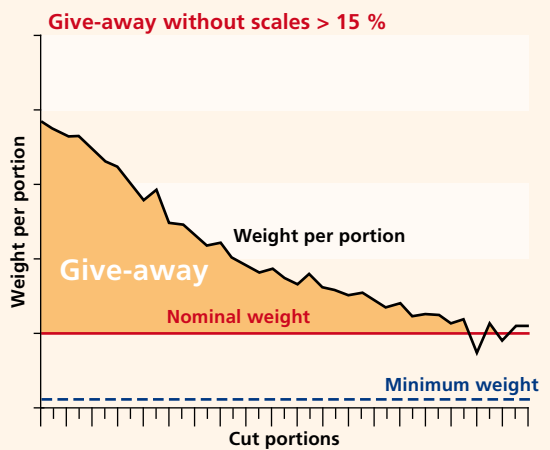

Its compact construction permits the use of Bizerba A 510 in small spaces with a width of only 80 cm.

... quality needs perfection ...

Well thought-out in ergonomics and work safety

Putting in heavy products is facilitated by a low chute; the pleasant height of the removal belt makes the removal of portions easy – completely without troublesome sticking of the product on account of the wire mesh. And if the products are not removed from the belt fast enough, this is registered by a light barrier. The cutting process is interrupted, which continues again automatically when the product has been removed. This function not only prevents sausage, ham and cheese from dropping off the belt, but also adapts the cutting speed to the cycle of the packaging process downstream.

Hygienic, practical, long-lived

The A 510 slicer meets the hygiene specifications in keeping with protection type IP X5 (hose water protection). It can be prepared for cleaning with a few simple movements and with little effort required, in particular. The product fixation, the product gripper and belts can be removed easily in order to be cleaned with pressurised water. In addition, the good accessibility to all areas of the machine requiring cleaning permits conventional cleaning at any time as well.

A class in itself

Smooth insensitive housing surfaces facilitate correct servicing considerably. And, if something does not work at some time, the Bizerba Service Department will help you fast and competently.

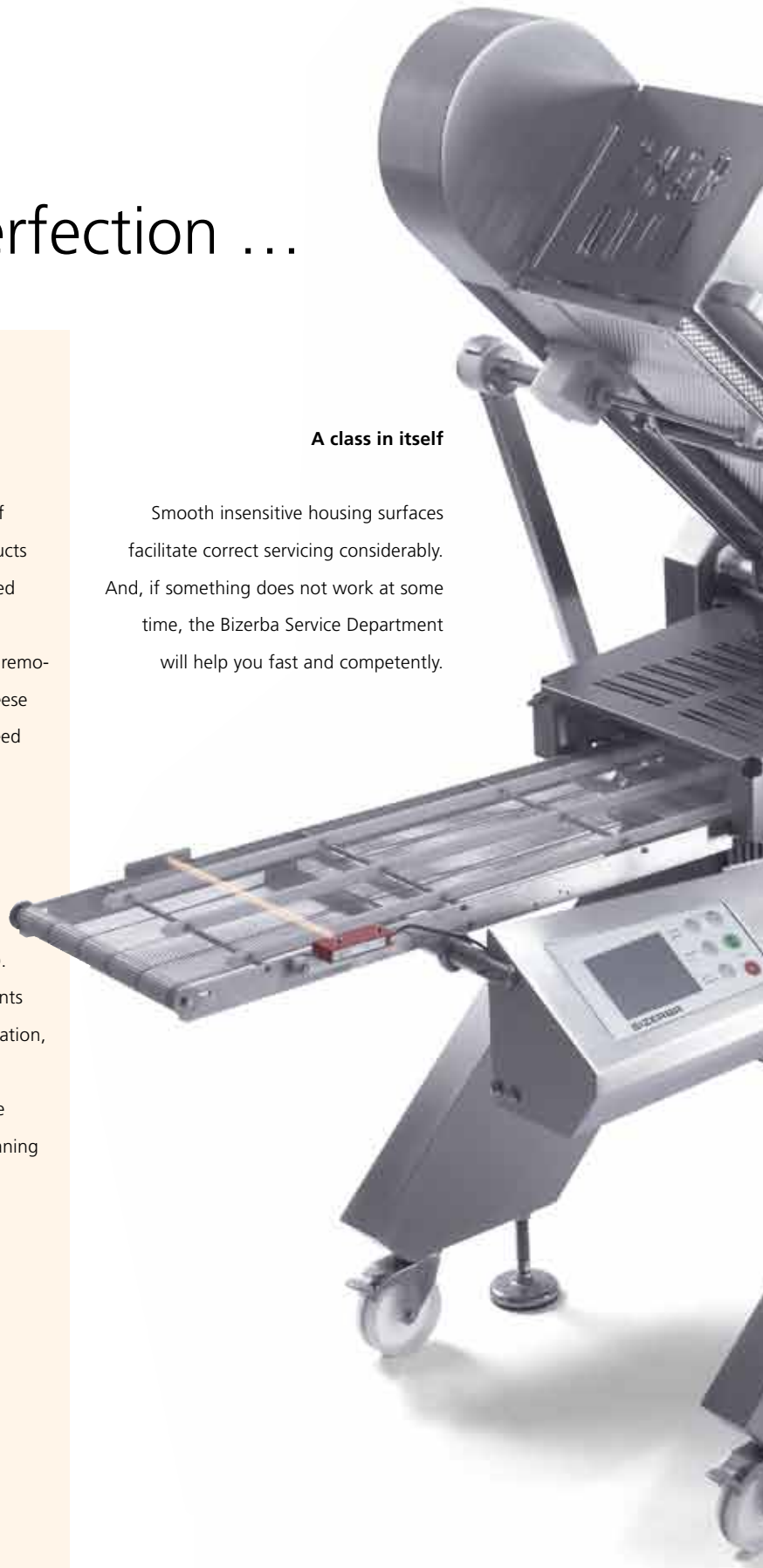

Feed

The product grippers with its quick-change system reduce the set-up time to a minimum in case of frequent product changes. The clamping device keeps products from 30 mm to 180 mm in height in place quickly and safely. The sensor-controlled product positioning system permits immediate cutting without empty cuts and moves the unit back automatically when the product has been cut up completely.

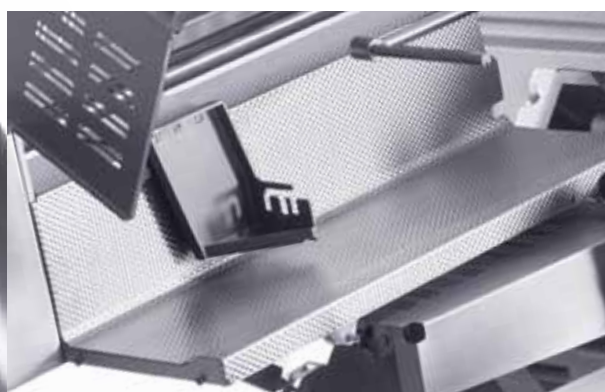

Cutting

The blade with a diameter of 420 mm can be sharpened directly on the machine by means of a quickly mounted grinding unit. Long down-times caused by circumstantial disassembly of the blade and permanent costs for sharpening service are things of the past.

The self-explanatory, clearly arranged and ergonomic touch screen panel and the well readable LCD sets the standard for user friendliness. Versatile programming options and cutting parameters will give you a lead over your competitors on account of high diverse performance.

... a whole range at the touch of a button ...

All cutting parameters are clearly arranged and displayed on the touch screen. Modifications are carried out directly on the touch screen. As all important parameters have been located on the topmost menu level, this is done in next to no time.

The different cutting programmes are entered, saved and sorted by means of alpha-numeric PLUs. The programme change is carried out by running a new PLU. And programme changes can be carried out equally easily.



Slices per minute

"Shingle" depositing pattern

Number of slices/portion

Slicing thickness in mm

Number of portions

Portion weight in grams

The weighing function of Bizerba A 510 can be tested completely free of charge first of all. Subsequently, this function has to be re-activated by paying a licence fee. Your Bizerba partner will be pleased to quote prices and terms.

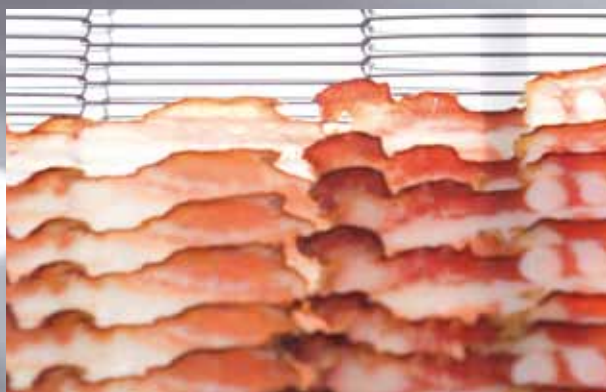
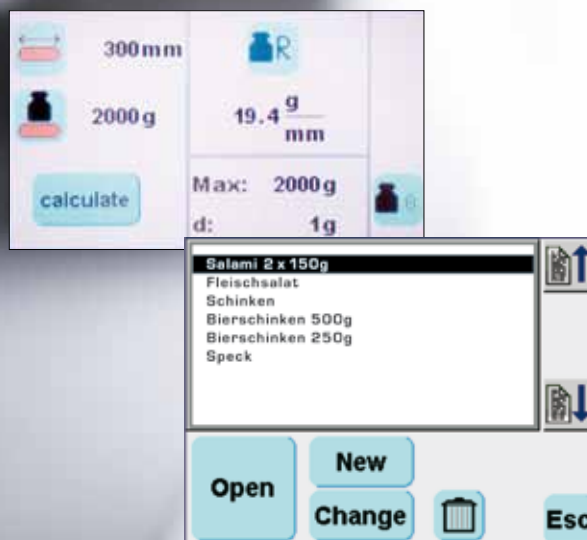

Weighing

As an optional feature, the scales can be activated by licence obtained from Bizerba. They permit a weight check directly on the belt slice by slice, even in case of irregular products, and with a guaranteed weight and portion accuracy as from 5 slices per portion. Depending on the requested portion weight, the thickness or the number of slices can be adjusted automatically during operation.

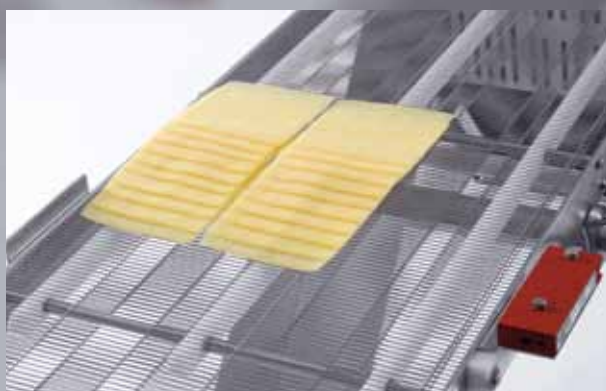

Depositing, transporting, packaging

The perfect co-operation between blade arm, belt drive and belt height adjustment lead to the best results in shingling and stacking. The transport system controlled by light barrier even recognises the speed of the operator and adjusts the further production consistently. Up to 200 slices per minutes can be cut, even if the weighing function is active. Product, number of slices, shingle distance, number of portions, distance of portions, slicing thickness, deposit patterns and stacks – up to 60 mm in height – everything can be defined variably.

Three-phase alternating current

Voltage (differs depending on country)

- 400 V

Frequency

- 50 Hz

Rated amperage

- 5.6 amps

Output

- 2.2 kW

Type of protection

- IP X5

Diameter of blade

- 420 mm

Maximum number of slices/minute

- 250 slices, 200 slices during weighing

Maximum product throughput

- Minimum diameter 40 mm; maximum diameter 180 mm
- 50 mm x 30 mm, max. 210 x 180 mm (W x H)

Adjustment of slicing thickness

- 0.5 to 30 mm

Shingle distance

- 3 to 30 mm

Maximum stacking height

- 60 mm

Maximum product length

- 600 mm

Display / keyboard

- Touch screen

Program memory

- Alpha-numeric program designations

External dimensions

- 2,320 x 800 x 1,835 mm (L x W x H)

Gross weight

- 628 kg including transport packaging

Shipping crate

- 2,120 x 920 x 1,700 mm

Separate units

- Separate sharpening unit, blade removal device

Accessories

- Portioning scales 2 kg, division 1 g, for the production of portions identical weight (uncalibrated); cheese blade; various conveying belt lengths

Retail concept of the next generation, complete from one source and with the know-how of the specialist for freshness

The high availability of your investment can be ensured easily and highly effectively in particular by preventive servicing and maintenance within the scope of the modular offer of Bizerba service agreements. The large range of services is supplemented by an extensive range of Bizerba accessories and attractive financing and leasing options of BLG Bizerba Leasing.

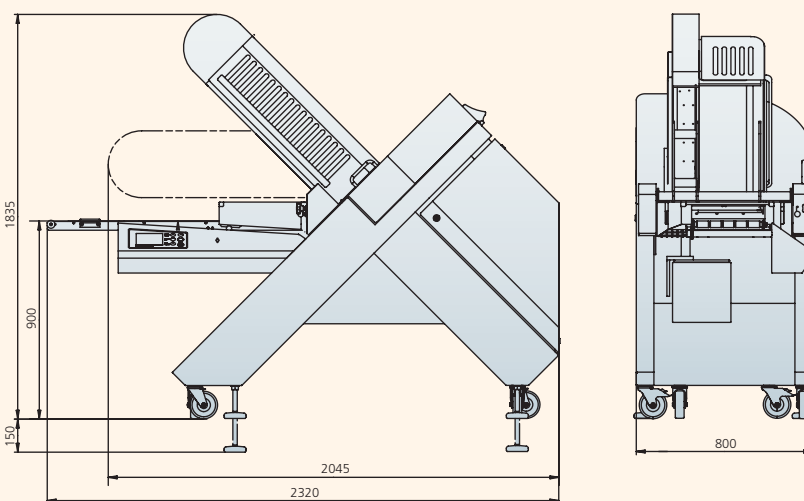

Members of the Bizerba Group

Bizerba GmbH & Co. KG
 Wilhelm-Kraut-Straße 65
 72336 Balingen
 Germany
 Tel. +49 7433 12-0
 Fax +49 7433 12-3010
 info@bizerba.de
 www.bizerba.com

Bizerba (U.K.) Limited
 Bizerba House
 Eastman Centre
 Eastman Way
 Hemel Hempstead
 Herts HP 2 7 DU
 U.K.
 Tel. +44 1442 24-0751
 Fax +44 1442 2313-28
 sales@bizerba.co.uk

Bizerba USA Inc.
 31 Gordon Road
 Piscataway
 New Jersey 08854
 USA
 Tel. Office +1 732 565-6000
 Tel. Service +1 732 565-6001
 Fax +1 732 819-0429
 us.info@bizerba.com
 www.bizerbausa.com

Bizerba Canada Inc.
 2810 Argenta Road #9
 Mississauga,
 Ontario L5N 8L2
 Canada
 Tel. +1 905 816-0498
 Fax +1 905 816-0497
 sales@bizerba.ca
 www.bizerba.ca

Bizerba South East Asia
 Pte. Ltd.
 1 Fifth Avenue #02-05
 Guthrie House
 Singapore 268802
 Singapore
 Tel. +65 6465-1900
 Fax +65 6468-0481
 bizerba@bizerba-sea.com
 www.bizerba-sea.com